

LTR	DATE	BY	CHECK	REVISIONS
A	8/17/00			INITIAL DESIGN
B	8/17/00			8-32 WAS 10-32
C	8/17/00			ADD 0.168 CBORE, PAN HEAD WAS NUTS

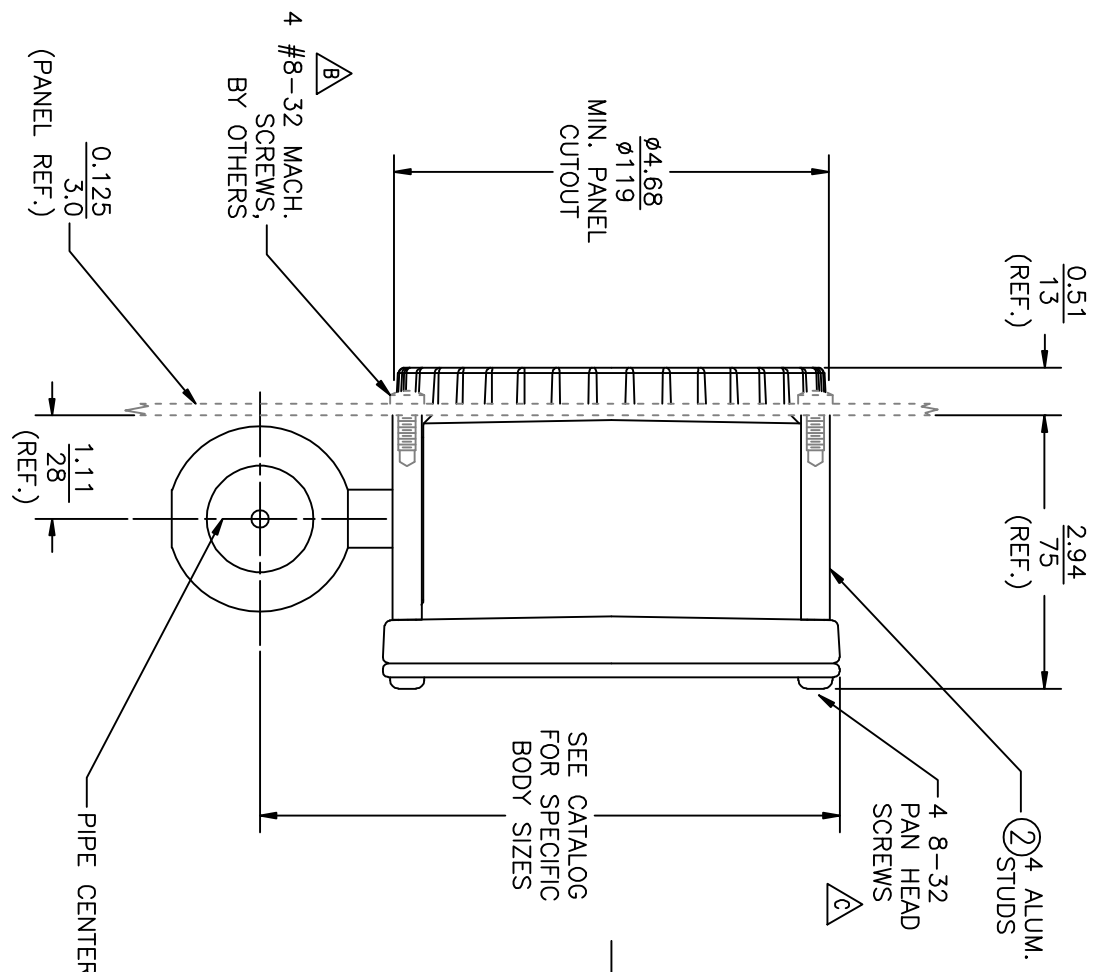

NOTES:
1. DIMENSION FORMAT $\frac{\text{in}}{\text{mm}}$

- $\triangle B$ 8-32 THRU PLASTIC
- $\triangle C$ 4 PLACES

ITEM	DWG. NO.	DESCRIPTION OF MATERIALS	QTY.
2	6402	STUDS, PANEL MOUNT	4
1	6130	HOUSING, ABS	1

UNLESS OTHERWISE SPECIFIED: DIMENSIONS ARE IN INCHES
FRACTIONS: $\frac{\#}{\#}$
X .XX
XX .XX
X .XX
X .XX
SURFACE FINISH: \checkmark

RCM *Industrial, Inc.* 110 MASON CIRCLE
CONCORD, CA. 94520

PANEL MOUNT HOUSING

CHECKED BY:
DRAWN BY:
DATE: 8/17/00
SCALE: 1:1 SIZE: C DWG. NO.: 6362 REV. C