



KUWAIT 3RD FLOW
MEASUREMENT TECHNOLOGY
CONFERENCE

19 - 21 NOVEMBER 2017

OFFICIAL SPONSOR



إحدى شركات مؤسسة البترول الكويتية
A Subsidiary of Kuwait Petroleum Corporation



ABDULRAHMAN ALABDULKARIM

Senior Measurement Engineer

Eastern Region Distribution Department (ERDD)





LATEST ARRANGEMENT FOR CUSTODY METERING SYSTEM OF REFINED HYDROCARBON PRODUCTS



OUTLINE

- **Refined Hydrocarbon Products Movement**
- **Factors Affecting Reliability of Metering System**
- **Latest Custody Metering System Arrangement**
- **Objectives & Challenges**
- **Conclusion**

REFINED HYDROCARBON PRODUCTS MOVEMENT

DOWNSTREAM

UPSTREAM

CUSTOMERS

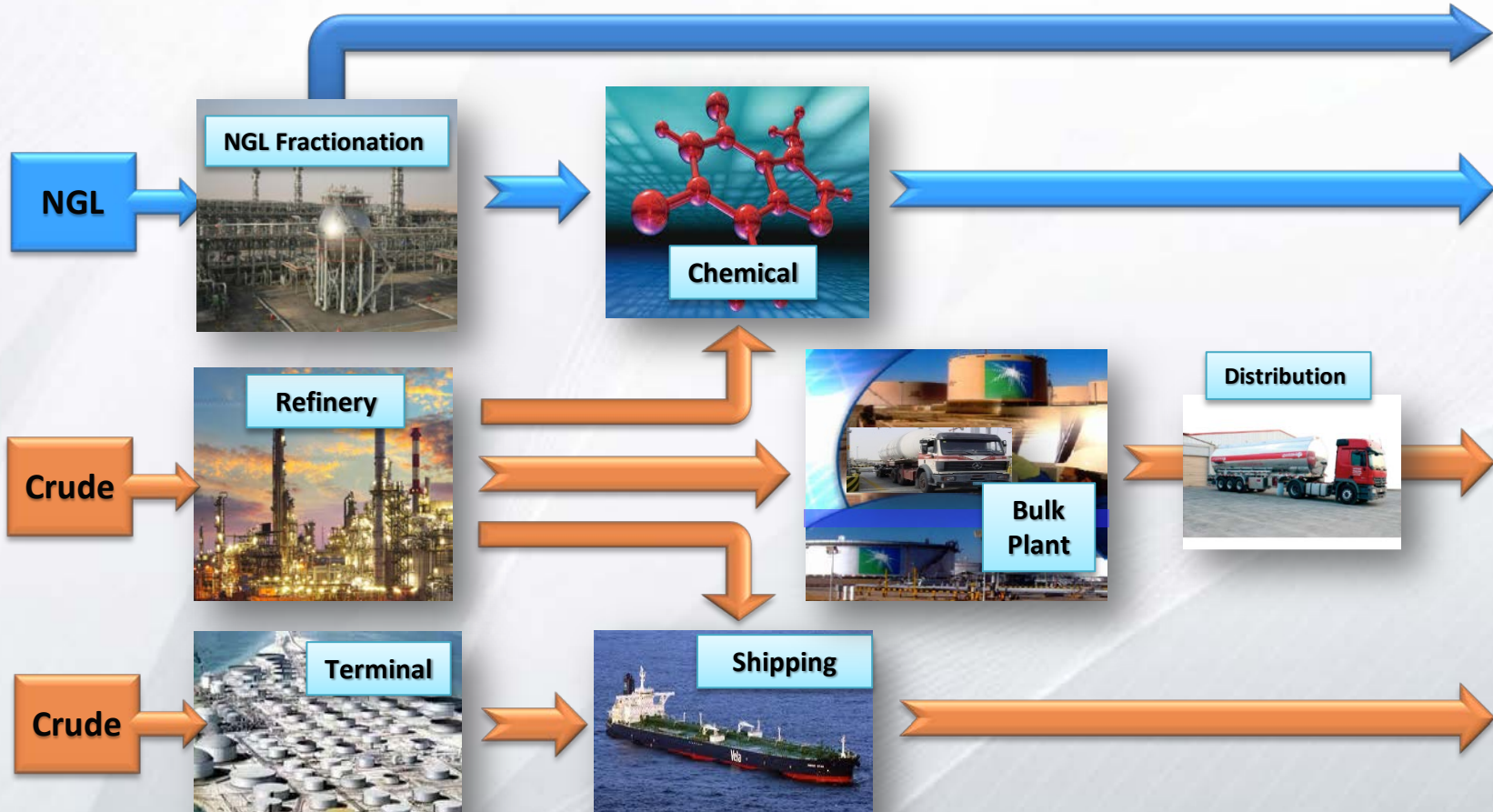

Oil & Hydrocarbon Products are transported over thousands of miles and change ownership many times.

REFINED HYDROCARBON PRODUCTS MOVEMENT

- Every segment of hydrocarbon products movement, the products batches are accurately measured, especially at the end, where the product sales to a third party required high attention.

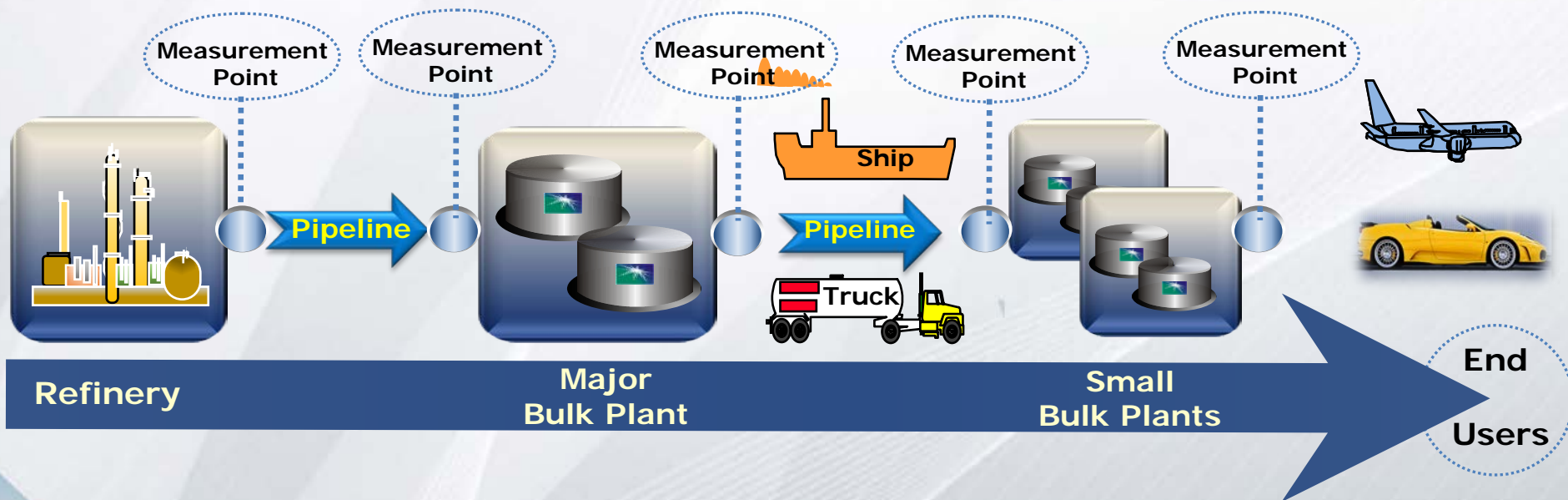

ERDD MISSION



Handle and distribute on-spec refined hydrocarbon products to committed demand centers through a competent workforce safely, environmentally friendly, reliably, efficiently and in a cost effective manner, to the satisfaction of customers.

FACTORS AFFECTING RELIABILITY OF METERING SYSTEMS

- **Continuity of operation & rate of flow**
 - **A metering system operating in a daily basis will be exposed to wear & fatigue.**
- **Non-Lubricating fluids**
 - **A metering system handle Non-lubricating fluid will most likely has a shorter seal life.**
- **Improper alignment**
 - **Lead to shaft & bearing damage**
- **Automatic system failure**
 - **Valve Body Damage**
 - **DP Transmitter frequent failure of the 4-way valve**

LATEST CUSTODY METERING SYSTEM ARRANGEMENT

الراعي الرسمي
OFFICIAL SPONSOR



WWW.KUWAIT-MEASUREMENT.COM

LATEST CUSTODY METERING SYSTEM ARRANGEMENT

Coriolis Meter



Small Volume Prover



LATEST CUSTODY METERING SYSTEM ARRANGEMENT

**4 Metering
Skids**



**4 Prover
Skids**



2 Control Panel



LATEST

CUSTODY METERING SYSTEM ARRANGEMENT

- 4 Metering Skids
- 4 Proving Skids
- 2 Control System Panels

Field Equipment



Control Panel

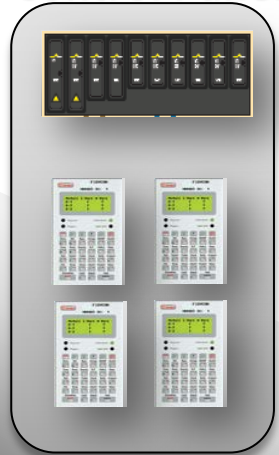

Control Room Equipment

PLC

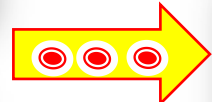

Flow Computers

Operator Workstations



Printers

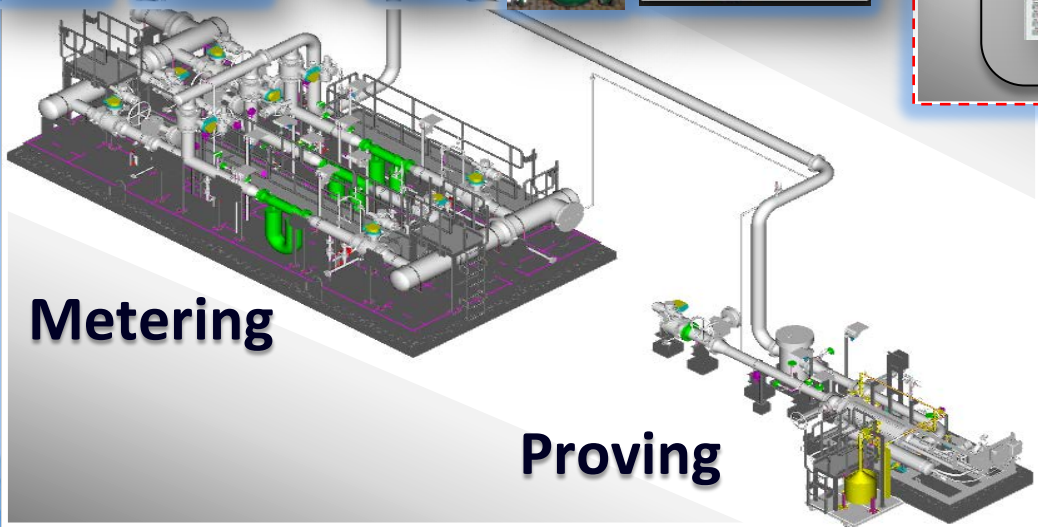

Metering

Proving

LATEST

CUSTODY METERING SYSTEM ARRANGEMENT

- 4 Metering Skids
- 4 Proving Skids
- 2 Control System Panels

Control Room Equipment

Operator Workstations

Control Panel



PLC

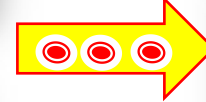

Flow Computers

Printers

METER TICKET
SAUDI ARABIAN OIL COMPANY (Saudi Aramco)
DELIVERY OR RECEIPT TICKET XXXX
OFFICIAL UNOFFICIAL

LOCATION: AAAAAA
DELIVERED TO/RECEIVED FROM: AAAAAA

METER MANUFACTURER: AA
METER MODEL: AA
METER SERIAL NUMBER: AA

PRIMARY FLOW COMPUTER: AA

DELIVERY/RECEIPT SUMMARY REPORT
SAUDI ARABIAN OIL COMPANY (Saudi Aramco)
BATCH NUMBER XXXX
MMDDYY HHMM

PROVING REPORT
SAUDI ARABIAN OIL COMPANY (Saudi Aramco)
REPORT NUMBER XXXXXX
OFFICIAL UNOFFICIAL

METER TAG NUMBER	TICKET NUMBER	D
AAAAAAA	XXXX	
AAAAAAA	XXXX	
AAAAAAA	XXXX	
AAAAAAA	XXXX	
AAAAAAA	XXXX	
AAAAAAA	XXXX	
AAAAAAA	XXXX	
AAAAAAA	XXXX	
AAAAAAA	XXXX	
AAAAAAA	XXXX	

TRIAL	LIQ.	RAI.	TOTAL	PRESS (mm)	PROVER	METER
1	XXXXXX.0	XXXXXX.0	XXXXXX.0	XXXX.0	XXXX.0	XXXX.0
2	XXXXXX.0	XXXXXX.0	XXXXXX.0	XXXX.0	XXXX.0	XXXX.0
3	XXXXXX.0	XXXXXX.0	XXXXXX.0	XXXX.0	XXXX.0	XXXX.0
4	XXXXXX.0	XXXXXX.0	XXXXXX.0	XXXX.0	XXXX.0	XXXX.0
10	XXXXXX.0	XXXXXX.0	XXXXXX.0	XXXX.0	XXXX.0	XXXX.0

METER TAG NUMBER	TICKET NUMBER	DENSITY at 15°C (Kg/M ³)	NET STANDARD VOLUME (M ³)
AAAAAAA	XXXX	XXXX.X	XXXXXXXX.XXX
AAAAAAA	XXXX	XXXX.X	XXXXXXXX.XXX
AAAAAAA	XXXX	XXXX.X	XXXXXXXX.XXX
AAAAAAA	XXXX	XXXX.X	XXXXXXXX.XXX
AAAAAAA	XXXX	XXXX.X	XXXXXXXX.XXX
AAAAAAA	XXXX	XXXX.X	XXXXXXXX.XXX
AAAAAAA	XXXX	XXXX.X	XXXXXXXX.XXX
AAAAAAA	XXXX	XXXX.X	XXXXXXXX.XXX
AAAAAAA	XXXX	XXXX.X	XXXXXXXX.XXX
AAAAAAA	XXXX	XXXX.X	XXXXXXXX.XXX

DELIVERY/RECEIPT SUMMARY REPORT
SAUDI ARABIAN OIL COMPANY (Saudi Aramco)
BATCH NUMBER XXXX
MMDDYY HHMM
TYPE OF LIQUID: AAAAAA

NON-NEGOTIABLE, NON-TRANSFERABLE
SAUDI ARABIAN OIL COMPANY
CHECKED FOR Saudi Aramco BY: DATE
WITNESSED BY: DATE

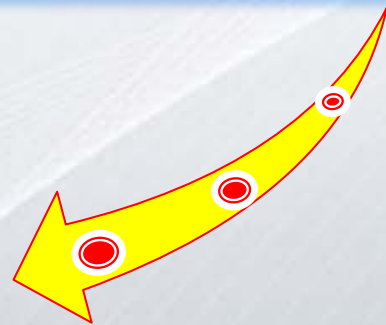

OBJECTIVES OF SELECTING METERING SYSTEM

- **Why Coriolis Meter & Small Volume Prover ?**
 - Enrich operation excellence through best practice
 - Avoid pipeline operation interruption
 - Reduce high maintenance cost
 - Stop using inefficient systems

OBJECTIVES OF SELECTING METERING SYSTEM

- Why Coriolis Meter & Small Volume Prover ?
- ~~It is designed to measure flow with high accuracy over a wide range of temperatures~~

Coriolis Meter

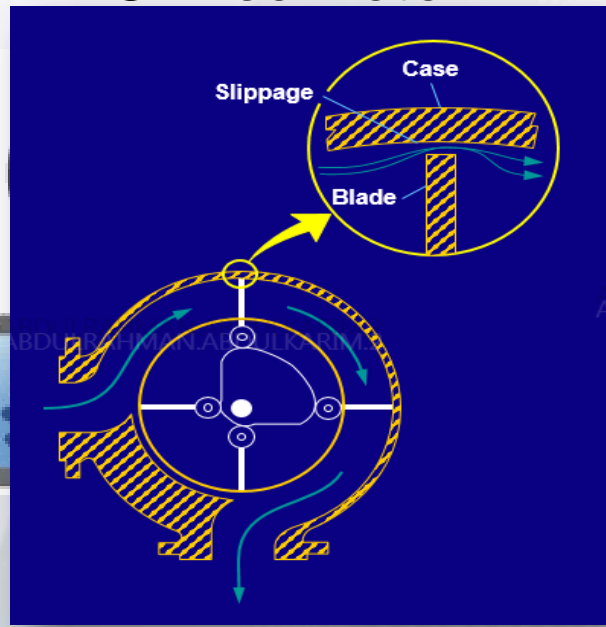

CHALLENGES OF SELECTING METERING SYSTEM

- Coriolis Meter is relatively new in the system
- Using Small Volume Prover for pipeline custody transfer

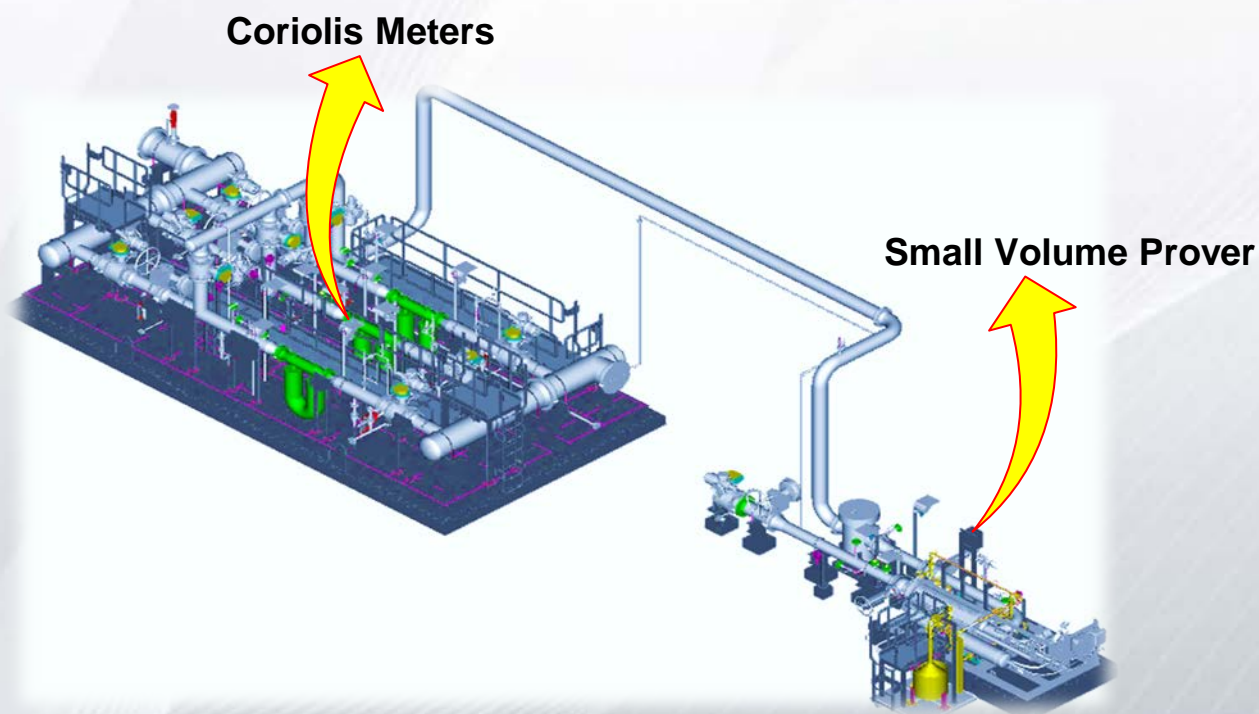

CONCLUSION

● Accurate and Defensible Measurement requires:

- Proper Design & Installation
- Appropriate & Very Accurate Equipment
- Adherence to Standards & Procedures
- Well-managed Operations & Maintenance
- Highly Trained Personnel
- Continuous Performance Monitoring

All aspects can be achieved. But, the most important is to maintain and sustain on the high performance.



Thanks for Your Attention

TURBINE METER PROBLEMS

- **Meter Impeller & Shaft**
Damage due to wear & fatigue

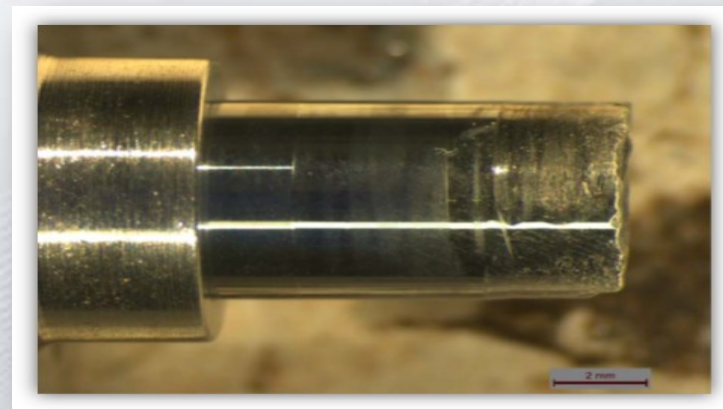
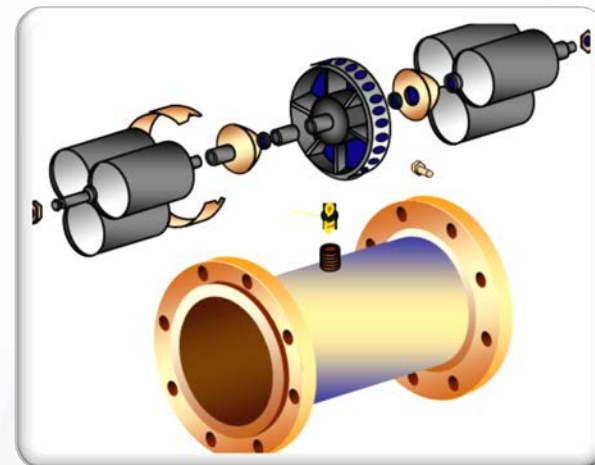

PROVER PROBLEM

● Four Way Valve

- Prover Seal Failure due to the fluid has no lubricity

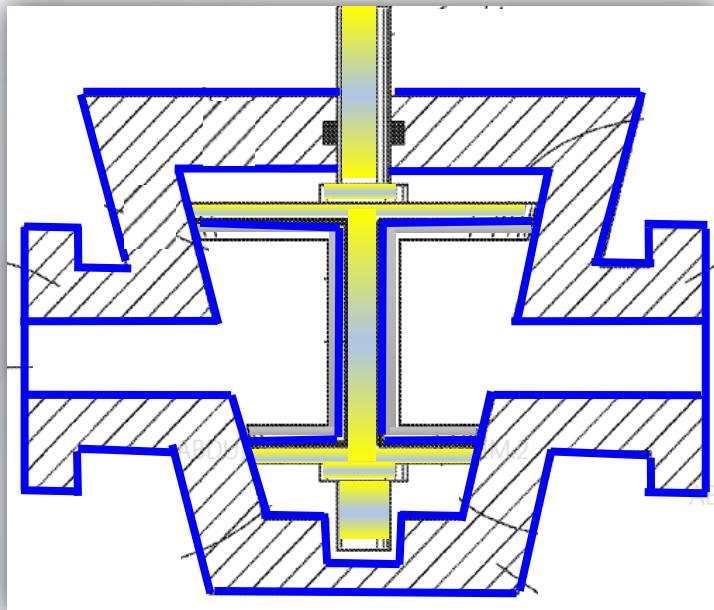

PROVER PROBLEM

● Prover Sphere

Sphere Rupture due to the fluids' low lubricity

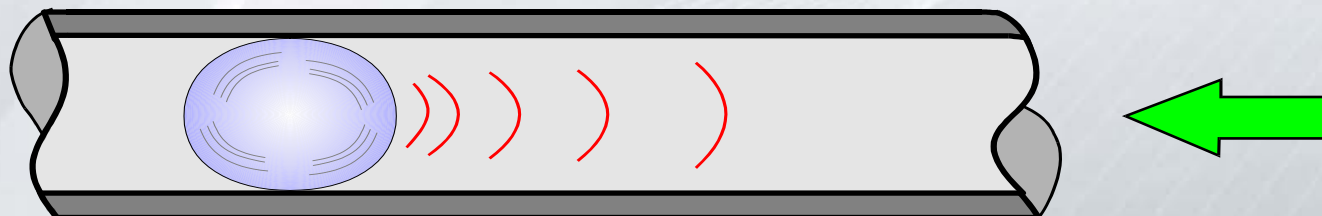

PROVER PROBLEM

● Four Way Valve

- Misalignment

Shaft & Bearing Damage due to shaft misalignment



PROVER PROBLEM

● Four Way Valve

- Valve Body Damage

The valve slips were lose and not retracting properly which led to sever damage.

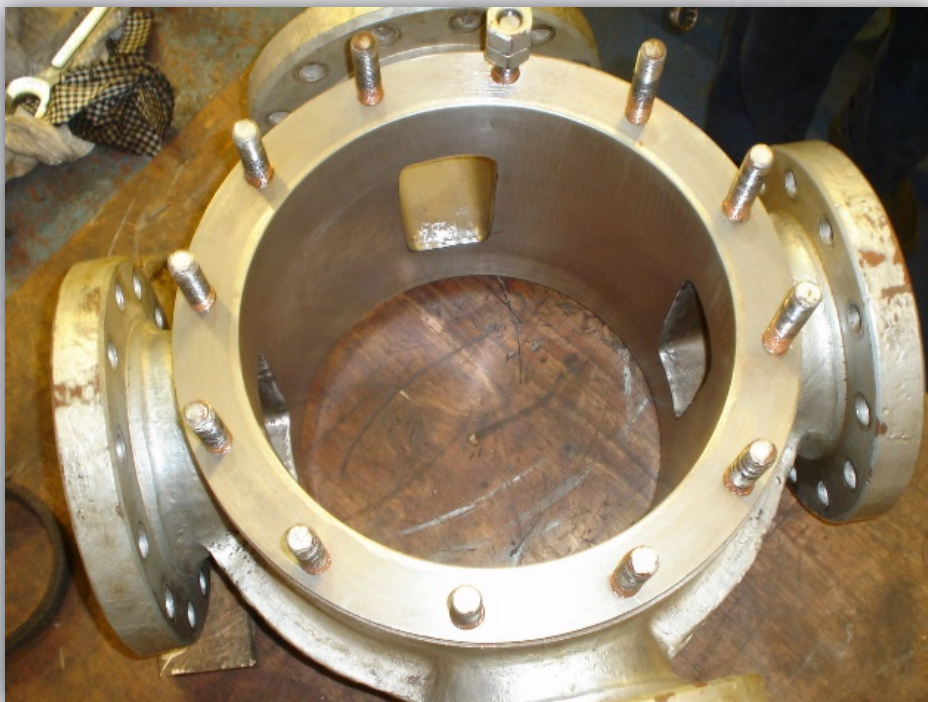

PROVER PROBLEM

● Four Way Valve

Require frequent maintenance

